

MOTOR DIMENSIONS

NEMA PREMIUM EFFICIENT JM FRAME 3 PHASE 3500 RPM

HP	Type	Frame	D	E	F	O	AB	BG	L	MH
2, 3	ODP	JM145	3.50	2.75	2.50	6.77	5.61	5.38	4.12	0.34
5	ODP	JM182	4.50	3.75	2.25	8.44	6.74	5.75	5.12	0.41
7.5	ODP	JM184	4.50	3.75	2.25	8.44	6.74	5.75	6.56	0.41
2	TEFC	JM145	3.50	2.75	2.50	7.00	6.25	5.06	6.34	.34
3	TEFC	JM182	4.50	3.75	2.25	8.85	7.57	5.01	7.14	.41
5, 7.5	TEFC	JM184	4.50	3.75	2.75	9.34	7.57	5.51	7.64	.41

D019GJM182

DRAWING DEPICTS 182JM 5.0HP ODP MOTOR

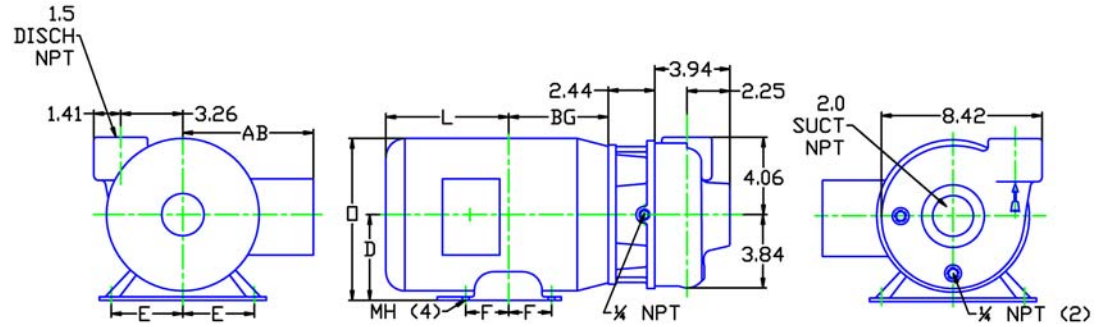

ALL DIMENSIONS IN INCHES.

DRAWING REPRESENTS APPROXIMATE PUMP DIMENSIONS. AUTOCAD DRAWINGS TO SCALE AVAILABLE FROM FACTORY

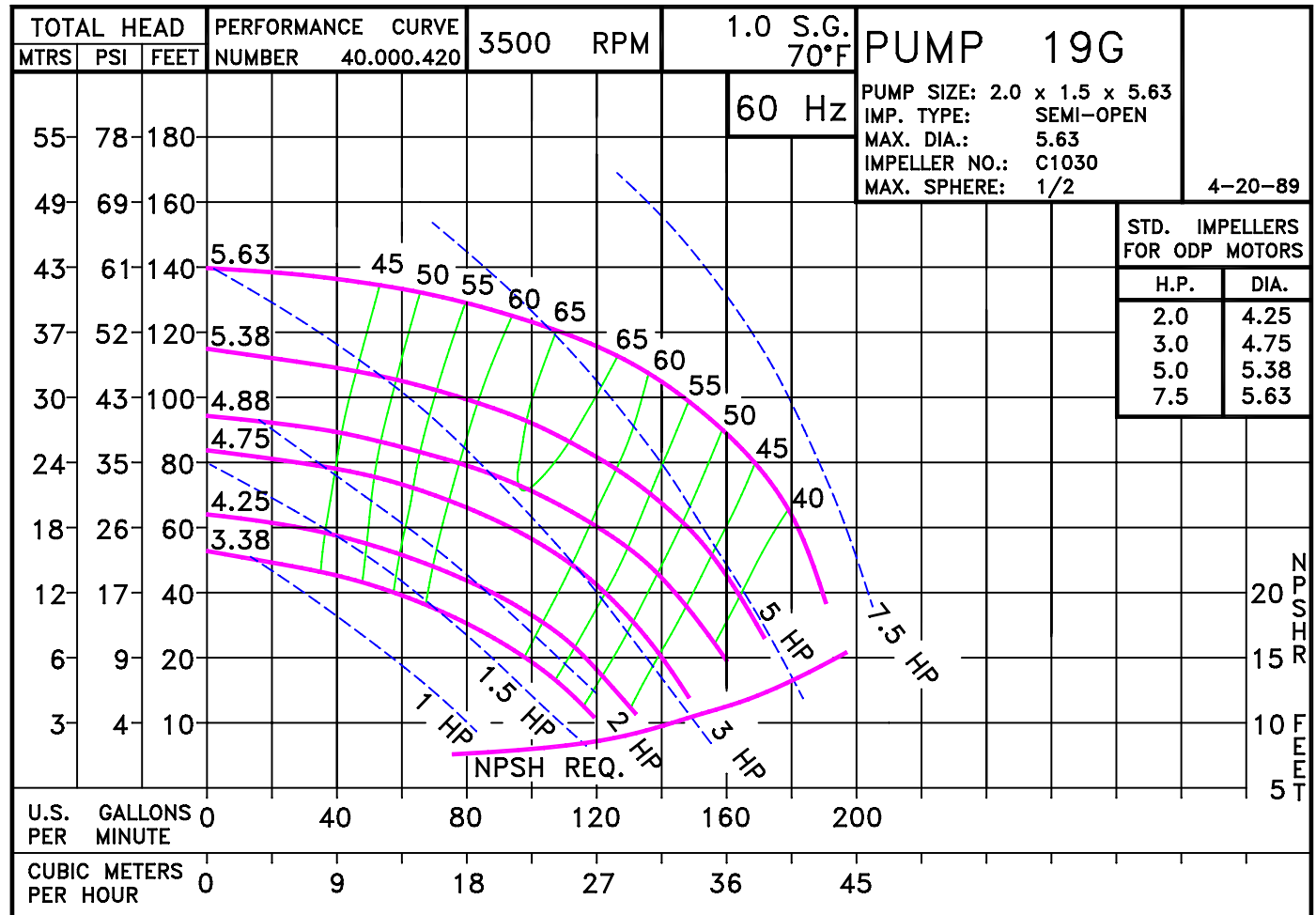

019G03DP

D019GJM182
019G3500

19G JM

019G3500JM
81.001.507 G16

Pump 19G • Iron • JM Frame • 3500 RPM

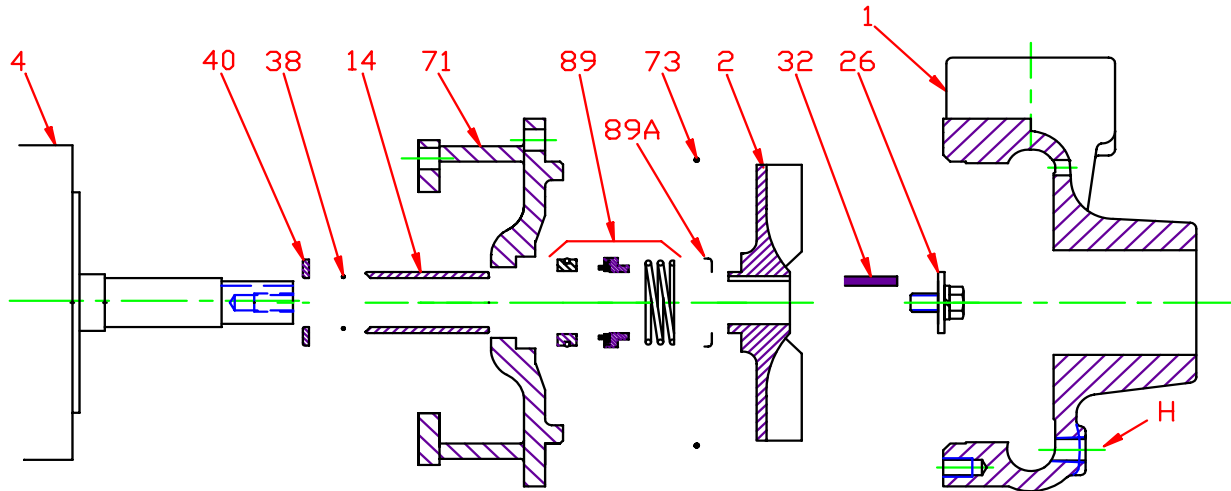

KEY NO.	PART NAME	PUMP NO. 19G
1	CASE, IRON, 2 x 1.5 NPT	130.000.344X
2	IMPELLER, 7/8" KEYED, SEMI-OPEN, SPECIFY DIAMETER:	
	IRON	137.000.135
	BRONZE	137.000.124
4	MOTOR, JM140/180	See Chart
14*	SHAFT SLEEVE, BRONZE	110.000.178
	SHAFT SLEEVE, STAINLESS	110.000.192
26*	IMPELLER RETAINER, STAINLESS	118.000.111A
32*	KEY, STAINLESS	102.000.102
38*	O-RING, SHAFT, BUNA	116.000.117
	O-RING, SHAFT, VITON	116.000.105
40*	FLINGER, STAINLESS	104.000.165
71	ADAPTER, IRON, JM140/180	132.000.194X
73*	GASKET, CASE, BUNA	116.000.146
89*	1½" SEALS:	
	BN-CARB/CM	101.000.168
	VN-CARB/CM	101.000.191
	VN-CARB/SIL	101.000.175
	VN-SIL/SIL	101.000.204
	EPDM-CARB/SIL	101.000.175B
	EPDM-SIL/SIL	101.000.204A
89A*	SEAL RETAINER	104.000.175
--	° REPAIR KITS:	
	BN-CARB/CM SEAL	118.000.343
	VN-CARB/CM SEAL (S)	118.000.343A
	VN-CARB/CM SEAL	118.000.343M
	VN-CARB/SIL SEAL	118.000.343B
	VN-SIL/SIL SEAL (S)	118.000.343F
	EPDM-CARB/SIL SEAL	118.000.343D
EPDM-SIL/SIL SEAL	118.000.343J	

* DENOTES COMPONENTS INCLUDED IN REPAIR KIT.
 ° ALL REPAIR KITS INCLUDE THE BRONZE SHAFT SLEEVE EXCEPT THE (S) INDICATED, WHICH IS STAINLESS WITH VITON SHAFT O-RING.

Pump 19G • Iron • JM Frame • 3500 RPM

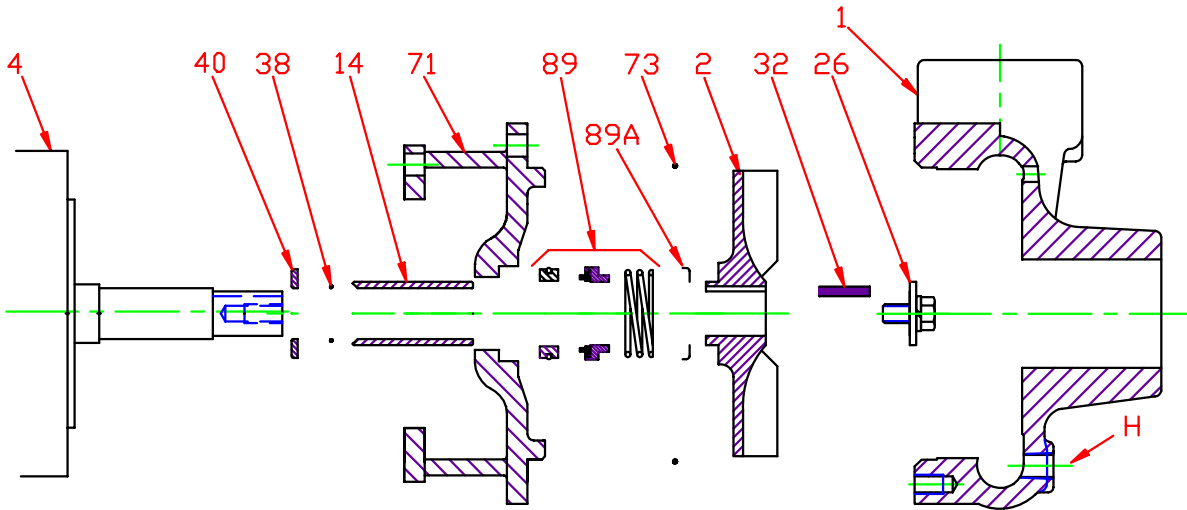

CONSTRUCTION OPTIONS

KEY	PART NAME	STANDARD FITTED	BRONZE FITTED	ALL IRON
1	Case	Iron	Iron	Iron
2	Impeller	Iron	Bronze	Iron
14	Shaft Sleeve	Bronze	Bronze	Stainless
26	Imp. Retaining Ass'y	Stainless	Stainless	Stainless
32	Key	Stainless	Stainless	Stainless
38	Shaft O-Ring	BUNA	BUNA	BUNA
40	Flinger	Stainless	Stainless	Stainless
71	Adapter	Iron	Iron	Iron
73	Gasket, Case	BUNA	BUNA	BUNA
89	Mechanical Seal, Type 21 BN-CM	Standard	Standard	Standard
89A	Seal Spring Retainer	Stainless	Stainless	Stainless
H	Plug, Drain	Brass	Brass	Plated Steel

E019JM

E11

C019G3500JM